

## QSFP28

### EQ23110X-3LCD10

#### 100G QSFP28 LR4 10KM Optical Transceiver

- Compliant with the QSFP28 MSA Technical Specifications
- Supports operation for a data rate of 103.1Gb/s
- Maximum link length of 10km on Single Mode Fiber (SMF).
- Optical specifications are compliant with IEEE802.3ba 100GBASE-LR4.
- Low speed electrical signal is compliant with SFF-8679.
- High speed electrical signal is compliant with 802.3bm CAUI-4.
- Digital diagnostic functions are available via the I2C interface, as specified by SFF-8636.
- 4x25Gb/s DFB-based LAN-WDM transmitter with central wavelengths of 4 channels •1295.56, 1300.05, 1304.58 and 1309.14 nm.
- Supports operation for a case temperature of 0°C to +70 °C.
- Duplex LC receptacles.
- Power Dissipation < 4W.
- Single 3.3V Power Supply.
- ROHS Compliant
- Monitor transceiver power and warn when threshold is exceeded



## Applications

- 100GBASE-LR4 Ethernet links

## Description

The QSFP28 LR4 is a 4x25G single-mode fiber, hot pluggable optical transceiver with unique technology enables the integration of 4 transmitters, 4 receivers and an optical MUX/ DeMUX into a small form factor package that delivers up to 112 Gbps data link in a compact QSFP28 footprint.

The optical connectivity is based on two Singlemode Fiber (SMF) LC connectors, one for Tx and one for Rx.

The Tx and Rx each consist of 4 25GB/s LAN-WDM channels, whose wavelengths are in the 1300nm range.

The QSFP28 LR4 transceiver is designed for applications with a reach up to 10Km.

## Absolute Maximum Ratings

Parameter	Symbol	Min	Max	Unit	Notes
Storage Temperature Range	T <sub>STG</sub>	-40	+85	°C	
Supply Voltage	V <sub>CC</sub>	0	4	V	
Maximum Average Input optical Power per Lane(Damage Threshold)	P <sub>IN</sub>	5.5		dBm	
Relative Humidity	RH	10% to 90% non-condensing			

## Operating Conditions

Parameter	Symbol	Min	Max	Unit	Notes
Case Temperature- Operating	T <sub>CASE</sub>	0	70	°C	
Supply Voltage	V <sub>CC</sub>	3.14	3.46	V	
Power Consumption	P <sub>DISS</sub>		3.5	W	
Power Consumption- LP Mode	P <sub>DISS-LP</sub>		1.5	W	

## 100GBASE-LR4 Operation

Transmitter Parameter	Lane	Min	Typical	Max	Unit	Notes
Signaling rate, each lane		25.73125±100 ppm			Gb/s	
Lane Wavelength Rang	Lane 0	1294.53	/	1296.59	nm	
	Lane 1	1299.02	/	1301.09	nm	
	Lane 2	1303.54	/	1305.63	nm	
	Lane 3	1308.09	/	1310.19	nm	
Average Optical Power per lane		-4.3		4.5	dBm	
Total Average Launch Power				10.5	dBm	

Optical Modulation Amplitude (OMA,each lane		-1.3		4.5	dBm	
Launch Power in DMA minusTDP,each lane		-2.3			dBm	
Transmitter andDispersion Penalty(TDP)each lane				2.2	dB	
Average Launch Power per Lane TX Off State				-30	dBm	
Extinction Ratio		4			dB	
Relative Intensity Noise(OMA)				-130	dB/Hz	
Side-Mode Suppression Ration(5MSR)		30			dB	
Optical Return Loss Tolerance				20	dB	
Transmitter Reflectance				-12	dB	
Transmitter Eye Mask Definition{X1,X2,X3,Y1,Y2,Y3	(0.25, 0.4, 0.45, 0.25, 0.28, 0.4}					1
Transmitter Dnput Power Monitor Accuracy		-3		3	dB	
Receiver Parameter	Lane	Min	Typical	Max	Unit	Notes
Signaling rate, each lane		25.78125±100 ppm			Gb/s	
Lane Wavelength Rang	Lane 0	1294.53	/	1296.59	nm	
	Lane 1	1299.02	/	1301.09	nm	
	Lane 2	1303.54	/	1305.63	nm	
	Lane 3	1308.09	/	1310.19	nm	
Damag Threshold		5.5			dBm	
Average Receive Power,each lane		-10.6		4.5	dBm	
Receive Power,each lane (DMA)				4.5	dBm	
Receiver Reflectance				-26.0	dB	
Receiver Sensitivity(OMA)per lane				-8.6	dBm	2
Stressed receiver sensitivity(DMA,each lane				-6.8	dBm	3
Receive Power Monitor Accuracy		-3.0		3.0	dB	

## Notes:

- 1.Hit ratio 5x10<sup>5</sup>
- 2.Measured with a test pattern of PRBS 231-1 at Pre-fec BER 1x10<sup>12</sup>
- 3.Measured with vertical eye closure penalty of 1.8 dB max, J2 of 0.30 UI, and J9 of 0.47 UI.

## QSFP28 Connector and Pinout Description

The electrical interface to the transceiver is a 38 pins edge connector. The 38 pins provide high speed data, low speed monitoring and control signals, I2C communication, power and ground connectivity. The top and bottom views of the connector are provided below, as well as a table outlining the contact numbering, symbol and full description.

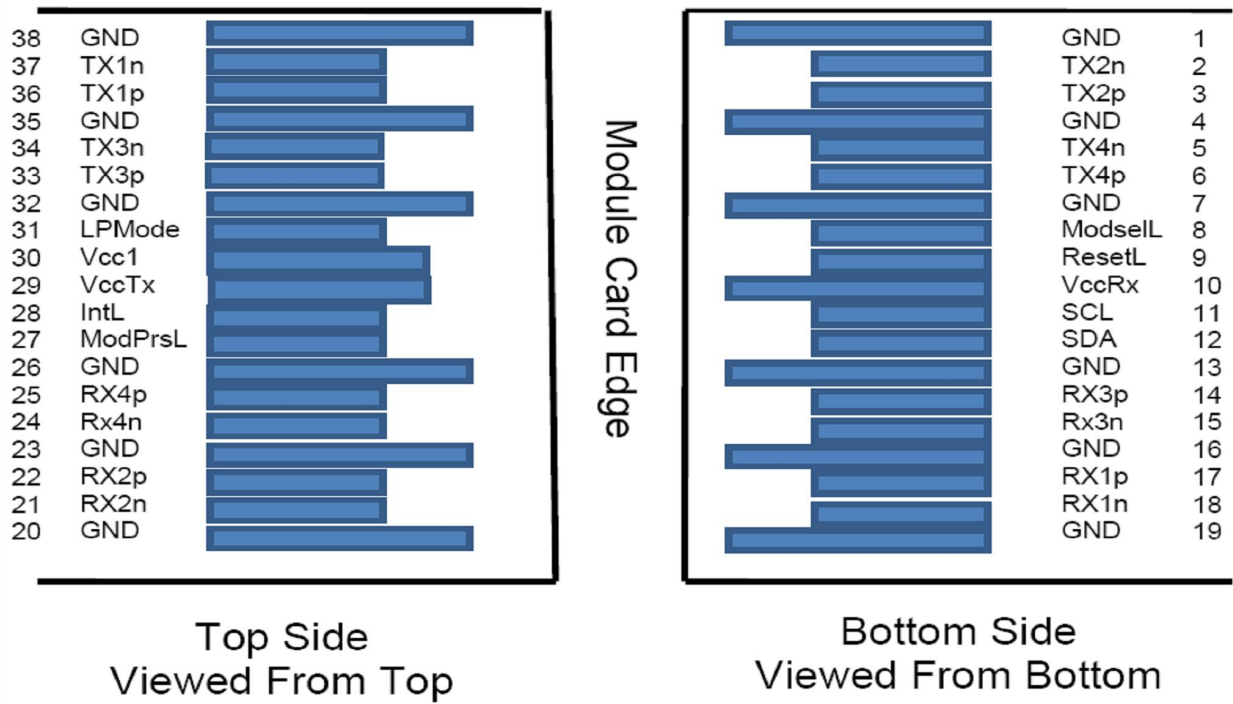

Figure 1. QSFP28-compliant 38-pin connector

## QSFP Transceiver Pinout

Pin No.	Logic	Symbol	Description	Plug Sequence
1		GND	Ground	1
2	CML-I	TX2n	Transmitted Inverted Data Input	3
3	CML-	TX2p	Transmitted Non-Inverted Data Input	3
4		GND	Ground	1
5	CML-I	TX4n	Transmitted Inverted Data Input	3
6	CML-I	TX4p	Transmitted Non-Inverted Data Input	3
7		GND	Ground	1
8	LVTTTL-	ModSeil	Module Select	3
9	LVTTTL-I	ResetL	MModule Reset	3
10		Vcc Rx	+3.3 VDC Receiver Power Supply	2
11	LVC MOS-I/O	SCL	Serial Clock for I2C Interface	3
12	LVC MOS-I/O	SDA	Serial Data for I2C Interface	3
13		GND	Ground	1
14	CML-0	RX3p	Receiver Non-Inverted Data Output	3
15	CML-0	RX3n	Receiver Inverted Data Output	3
16		GND	Ground	1
17	CML-0	RX1p	Receiver Non-Inverted Data Output	3
18	CML-0	RXin	Receiver Inverted Data Output	3
19		GND	Ground	1
20		GND	Ground	1
21	CML-0	RX2n	Receiver Inverted Data Output	3

22	CML-0	RX2p	Receiver Non-Inverted Data Output	3
23		GND	Ground	1
24	CML-0	RX4n	Receiver Inverted Data Output	3
25	CML-0	RX4p	Receiver Non-Inverted Data Output	3
26		GND	Ground	1
27	LVTTTL-0	ModPrsL	Module Present	3
28	LVTTTL-0	IntL	Interrupt	3
29		Vcc Tx	+3.3 VDC Transmitter Power Supply	2
30		Vccl	+3.3 VDC Power Supply	2
31	LVTTTL-I	LPMode	Low Power Mode	3
32		GND	Ground	1
33	CML-	TX3p	Transmitted Non-Inverted Data Input	3
34	CML	TX3n	Transmitted Inverted Data Input	3
35		GND	Ground	1
36	CML-	TX1p	Transmitted Non-Inverted Data Input	3
37	CML-I	TX1n	Transmitted Inverted Data Input	3
38		GND	Ground	1

## Electrical Characteristics

Transmitter electrical input signal characteristics(TP1)	Min	Typical	Max	Unit
Signaling rate per lane (range)	25.78125 ± 100 ppm			GBd
Differential input return loss	Equation (83E-5)			dB
Differential to common mode input return loss	Equation (83E-6)			dB
Differential termination mismatch			10	%
Module stressed input test	See 83E3.4.1			
Differential pk-pk input voltage tolerance	900			mV
DC common mode voltage	-350		2850	mV
Single ended voltage tolerance range	-0.4		3.3	V
Receiver electrical output signal characteristics(TP4)	Min	Typical	Max	Unit
Signaling rate per lane (range)	25.78125 ± 100 ppm			GBd
AC common-mode output voltage (RMS)			17.5	mV
Differential output voltage			900	mV
Eye width	0.57			UI
Eye height, differential	228			mV
Vertical eye closure			5.5	dB
Differential output return loss	Equation (83E-2)			dB
Common to differential mode conversion return loss	Equation (83E-3)			dB
Differential termination mismatch			10	%
Transition time (20% to 80%)	12			ps
DC common mode voltage	-350		2850	mV

## Functional Block Diagram

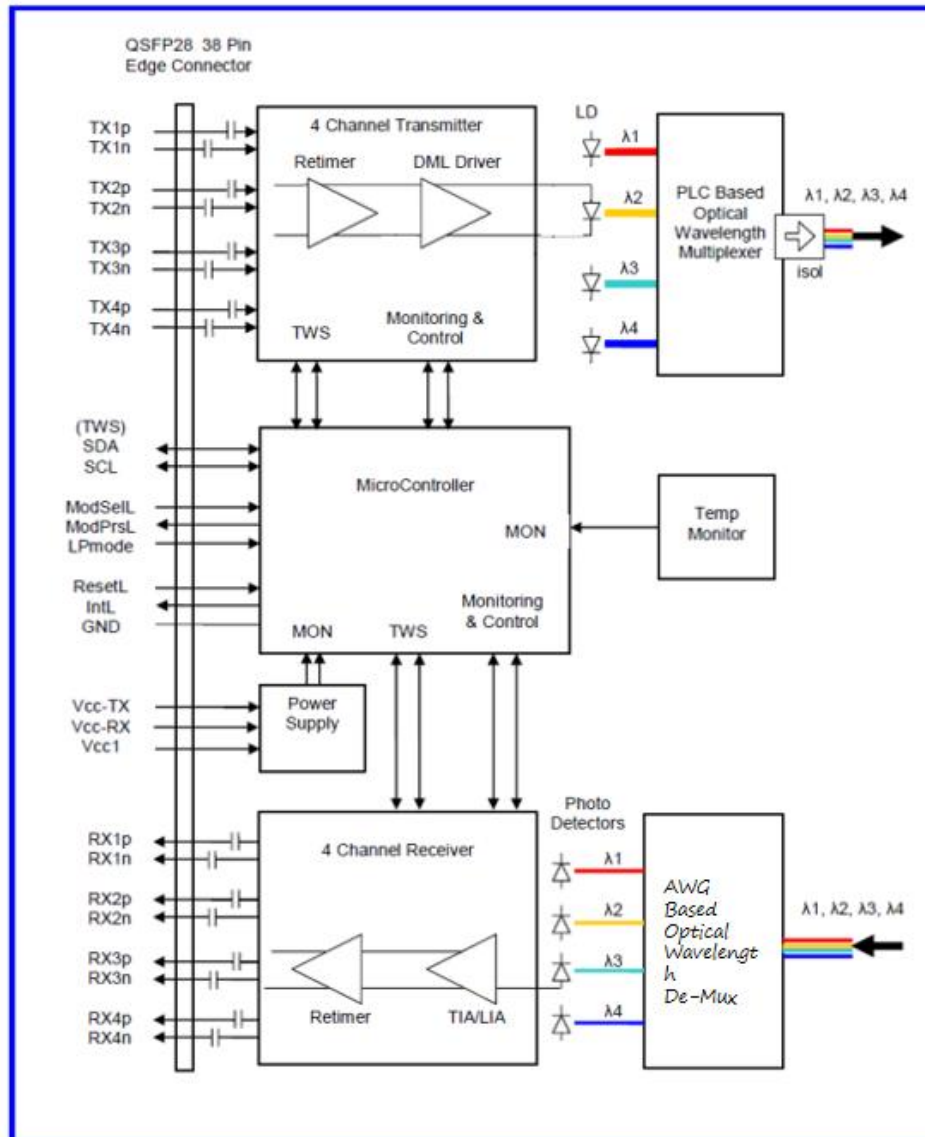

Figure 2. Functional Block Diagram

## Mechanical Specifications

Unit: mm

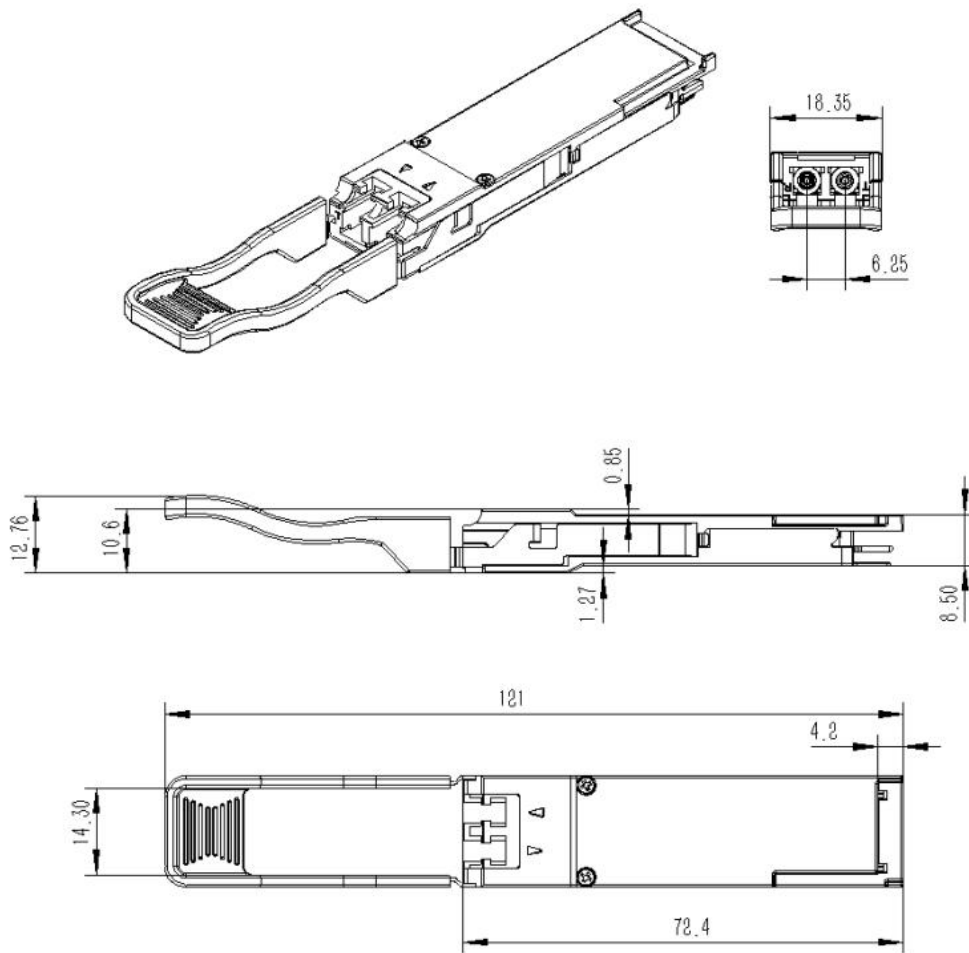

Figure 3. Mechanical Dimensions

## Compatibility Test

In order to ensure the product compatibility, our products will be tested on the switch before shipment. Our modules can compatible with many mainstream brand switches, such as Cisco, Juniper, Extreme, Brocade, IBM, H3C, HP, Huawei, D-Link, Mikrotik, ZTE, TP-Link...

Our test equipment: VOLKTEK MEN-4110, HP 2530-8G, CRS226-24G-25+RM, Catalyst 2960G Series, Catalyst 3850 XS 10G SFP+, Catalyst 3750-E Series, HUAWEI S5700Series, H3C S3100V2 Series, Juniper-EX4200, etc.



**Cisco Catalyst 3850**



**HUAWEI S5700**



**H3C S3100V2**



**HP J9264AR**



**Juniper EX 4200**



**Alcatel 6850E-U24X**



**Mikrotik CR5226-24G-25+RM**



**Cisco Catalyst 2960G**



**Volktek MEN-4110**



## Product Production Process

# Quality Assurance

Continuous introduction of new equipment, produced by strict standards, strict quality inspection, to guarantee the high quality standard of each product.



**Standardized  
Production Line**



**Professional  
Welding**



**Assembling**



**Aging Testing**

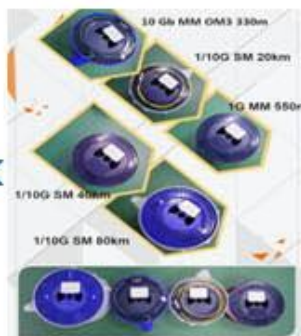

**Distance Testing**



**Cleaning end face**



**Product Initial Test**



**Switch Testing**



**Product Final Test**

## Packaging

ETU-Link provides two kinds of packaging, 10pcs/Tray and individual package.



Company: ETU-Link Technology Co., LTD

Address: Right side of 3rd floor, No. 102 building, Longguan expressway, Dalang street, Longhua District, Shenzhen city, Guangdong Province, China

Tel: +86-755 2328 4603

Addresses and phone number also have been listed at [www.etulinktechnology.com](http://www.etulinktechnology.com).

Please e-mail us at [sales@etulinktechnology.com](mailto:sales@etulinktechnology.com) or call us for assistance.